

Orbital welding (Open heads)

AXXAIR
INNOVATIVE ORBITAL SOLUTIONS

Our range of open welding heads (SATO series) allows you to make very high quality welds in a minimal space.

On these heads you will find a mechanical tracking system to keep a constant arc height. The torch can tilt to weld at an angle.

Open heads are mainly recommended for the agro-food, pharmaceutical, chemical sectors, for wall thicknesses less than but also greater than 3 mm.



This type of machine can be used to weld carbon steel tubes.

Open heads offer very wide welding possibilities thanks to the inclination of the torch and the addition of filler metal. The clamping range is achieved without the addition of jaws.

The tracking system is by roller so as not to scratch the tube. All the parts in contact with the tube are made of stainless steel so as not to contaminate it.

With its unique symmetrical clamping system, its stepping motor control, this range offers a very wide range of use.

You can choose between heads provided with or without an AVC/OSC system.

FLEXIBILITY, PRODUCTIVITY

AXXAIR open heads are available with or without filler metal. They have an optimized rotation sweep and 2 positions of feed motor to choose from. High duty cycle (water cooled torch).

QUALITY AND REPEATABILITY

The SATO range is connected to our orbital generators, which permanently control all the welding parameters, guaranteeing repeatable and quality welds.

PORTABILITY

In order to allow you to weld in restrictive conditions and locations, the size of rotating elements and the weight of the machines have been optimized. Our machines are supplied with integrated remote control and 5 m welding cable allowing the operator to work remotely from the generator.

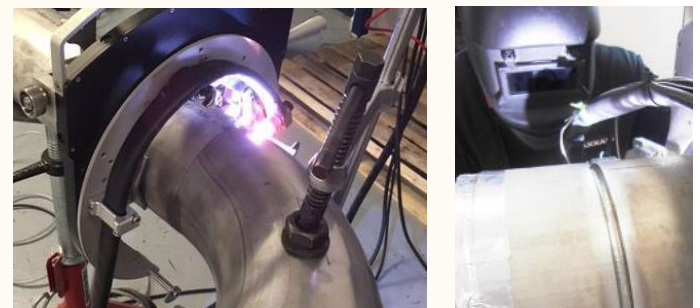

Please do not hesitate to contact us for all enquiries relating to orbital welding technology.

We will be glad to share our know-how with you and to devise a solution that best meets your needs!



SATO-40 - 80 - 115 - 170 - 220

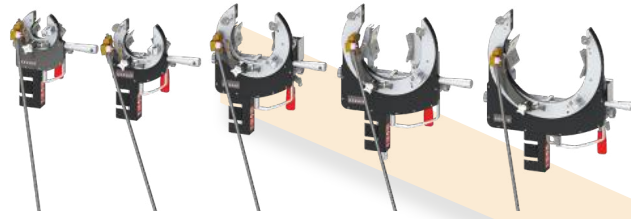

Water Cooled



Roller mechanical profile tracking

Constant arc voltage without marking the tube

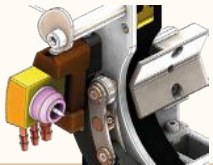

Compatible With the SAXX generators



Transport

These heads are delivered in their individual transport case



Straight or Angled motor
Symmetrical clamping

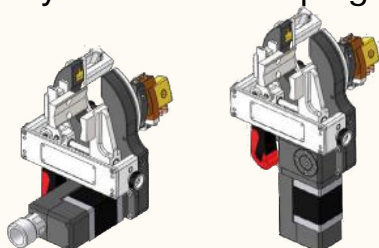

Axial Adjustment

Wheel for axial adjustment of the position of the electrode

Protection

High protection against arcing outside the electrode

Torch angle adjustment

Welding flanges and short T angle



Locked open position

Motorization with encoder

Allows STARTING IN ALL ANGULAR electrode positions

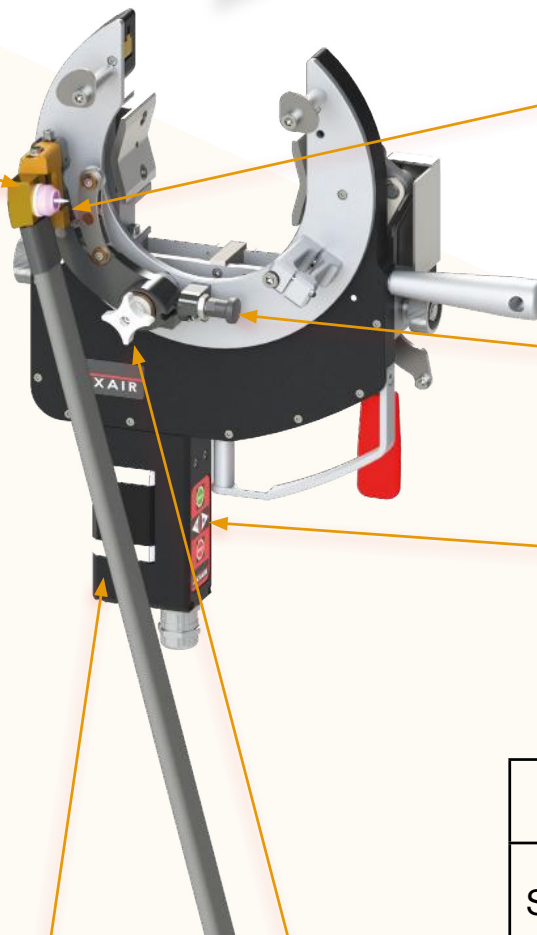

Welding range	
SATO 40	∅ 10 - ∅ 40 mm 0.4- 1.5 "
SATO 80	∅ 19 - ∅ 80 mm 0.75 - 3 "
SATO 115	∅ 19 - ∅ 115 mm 0.75 - 4.5 "
SATO 170	∅ 25 - ∅ 170 mm 1 - 6.625 "
SATO 220	∅ 38 - ∅ 220 mm 1.5 - 8.265 "



SATO-40 - 80 - 115 - 170 - 220**AXXAIR**
INNOVATIVE ORBITAL SOLUTIONS

Moteur	Cooling	Product Code	Welding machine for tubes of the following diameters (in mm)	Net weight	Customs code	Dimensions (AxBxC in mm)
Angled motor	WATER	SATO-40E42	ø 10 - ø 40 mm	3.8 kg	85153 10000	169 x 183 x 142
		SATO-80E42	ø 19 - ø 80 mm	4.2 kg		181 x 186 x 160
		SATO-115E42	ø 19 - ø 115 mm	6.7 kg		265 x 186 x 230
		SATO-170E42	ø 25 - ø 170 mm	8 kg		312 x 186 x 290
		SATO-220E42	ø 38 - ø 220 mm	9.4 kg		353 x 186 x 350
Straight motor	WATER	SATO-40E41	ø 10 - ø 40 mm	3.8 kg	85153 10000	169 x 191 x 142
		SATO-80E41	ø 19 - ø 80 mm	4.2 kg		181 x 196 x 160
		SATO-115E41	ø 19 - ø 115 mm	6.7 kg		265 x 196 x 230
		SATO-170E41	ø 25 - ø 170 mm	8 kg		312 x 196 x 290
		SATO-220E41	ø 38 - ø 220 mm	9.4 kg		353 x 196 x 350



AXXAIR's orbital welding

Sweep Multi-pass TIG welding

- AVC/OSC system -

AXXAIR

INNOVATIVE ORBITAL SOLUTIONS

Motorised voltage control: AVC

Motorised Arc Voltage Control is often abbreviated to AVC. Arc voltage is directly linked to the distance between the tube to be welded and the electrode. In other words, this option ensures the correct tube-electrode distance is maintained electronically during welding.

AVC can indeed be of huge benefit, especially in mechanised welding, and the more sensors there are to guide the machine, the less user intervention is required.

The two most frequent applications:

- When you do not wish to measure the external diameter physically using a feeler probe; AVC requires no contact with the tube and the sensor is more accurate and responsive than with physical tracking.

- When wire welding and the deposition rate beneath the electrode is not fully controlled, this can obviously affect the arc length. In this case, AVC means you never go near the soldering bath.

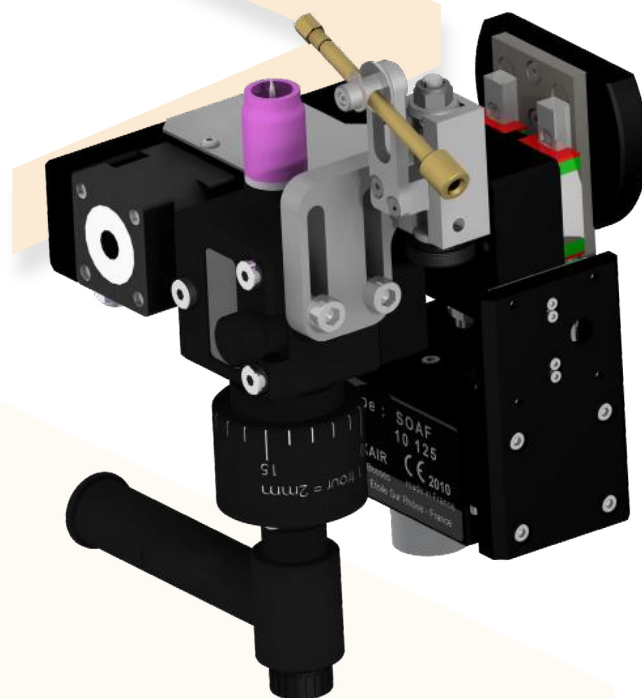
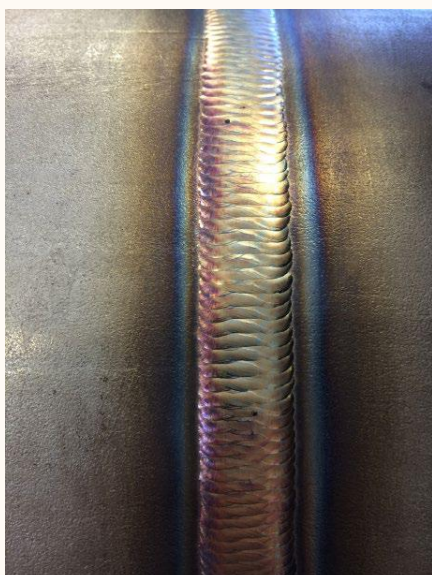

Fusion+OSC+wire:

This welding method combines AVC movement with oscillation of the torch and wire. This method is used for multi-pass welding of high thickness materials.

Torch oscillation is where the electrode is swung left and right in a linear motion so that each side of the joint can be kept liquid as welding progresses.

Oscillation brings an improvement in the number of passes, and therefore significantly improves productivity.

This system, when combined with AVC, is the only effective way of filling a tulip joint in multi-pass TIG welding.

These systems are available on prefabrication machines and open heads.



SATO-115 - 170 -220 (AVC/OSC)



Control of the wire

regulation of the wire by the SAXX generators

Water Cooled

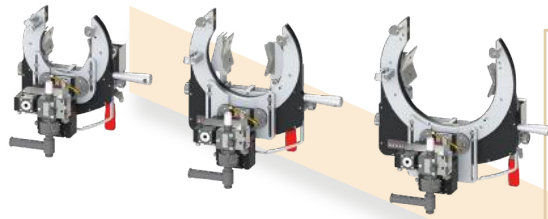

Protection

High protection against arcing outside the electrode

Multi-pass welding

Mortorised axial sweep (OSC)

Movement of the electrode's axial position: +/- 10 mm

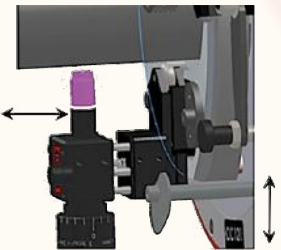

Constant distance: electrode-tube

Motorised setting and control of the distance tube-electrode (AVC)

regulates the arc voltage, the distance between the electrode and the tube

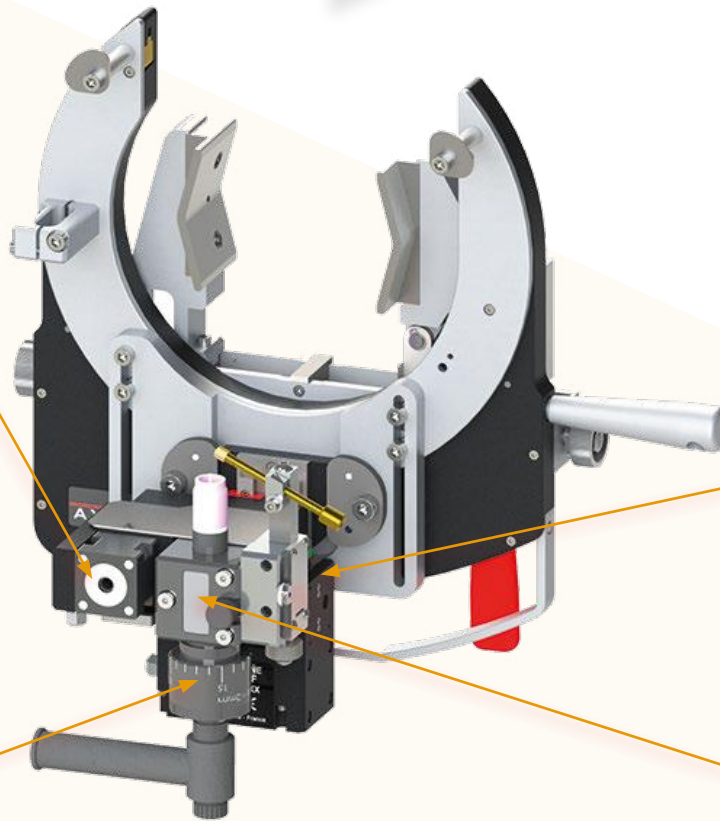

Transport

These heads are delivered in their individual transport



Motorization with encoder

Allows STARTING IN ALL ANGULAR electrode positions

AVC/OSC system

Allows to weld tubes with up to 12.7 mm wall thickness

Straight or Angled motor

Symmetrical clamping

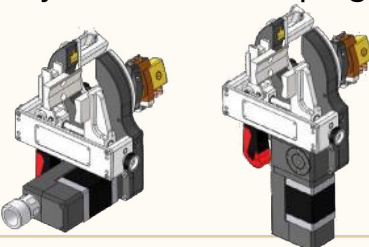

Compatible with the 210 and 300 SAXX generators



Welding range

SATO 115	∅ 19 - ∅ 115 mm 0.75 - 4.5 "
SATO 170	∅ 25 - ∅ 170 mm 1 - 6.625 "
SATO 220	∅ 38 - ∅ 220 mm 1.5 - 8.265 "



SATO-115 - 170 -220 (AVC/OSC)

Caractéristiques techniques:

- WATER cooled head with AVC/OSC system
- Quick symmetrical tightening by lever
- Motorization with encoder: allows starting from any angular position of the electrode
- Wide diameter range
- For optimum use, the ambient temperature must be between 0 °C and + 40 °C.
- Oscillation range: 20 mm, AVC range: 20 mm, max speed: 15 mm/s
- Machines compatible with AXXAIR welding power sources with SAXX (210 and 300) type liquid coolant system for welding cycle.

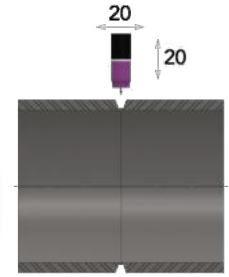

Choice of two different models (to choose according to your applications)

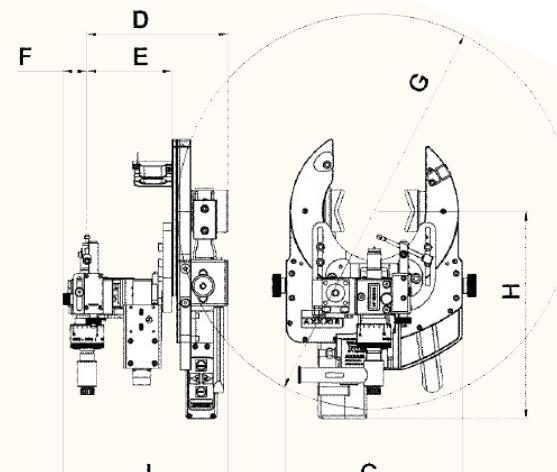

SATO-xxE52 (water cooled with AVC / OSC system)

Angled output motor

SATO-xxE51 (water cooled with AVC / OSC system)

Straight output motor

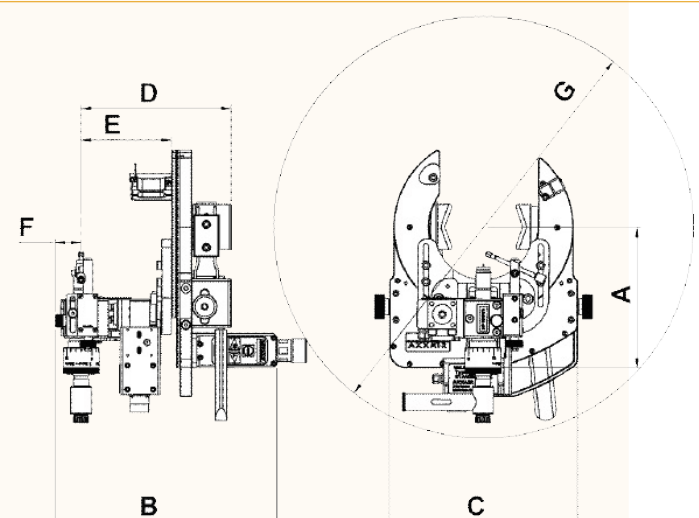

	A mm	B mm	C mm	D mm	E mm	F mm	G mm	H mm	I mm
SATO-115	171	246-271	230	146-171	85-110	31.5	680	269	194-219
SATO-170	201		290				750	299	
SATO-220	220		350				800	318	

