

CERBACO LTD.

***STANDARD NON METALLIC WELD BACKINGS
FOR FULL PENETRATION WELDING***

WELD MORE EFFICIENTLY !

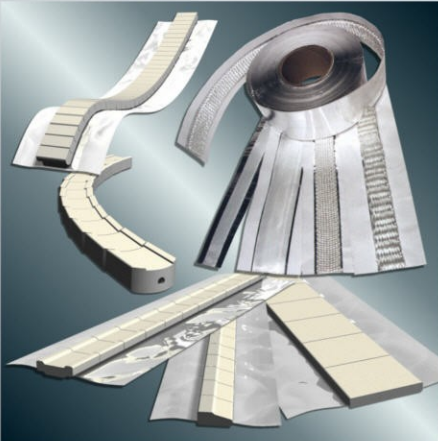

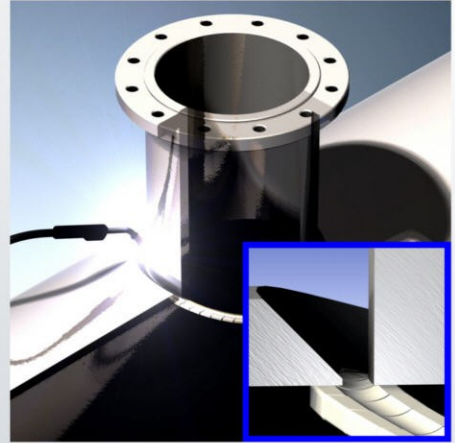















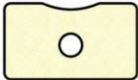







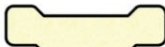

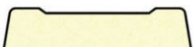

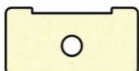
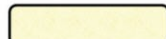
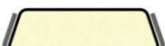

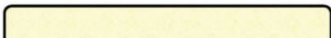



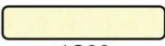

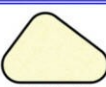

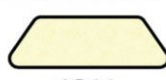

MADE IN U.S.A.

Distribuidor para Colombia:



www.daonte.com
info@daonte.com
Cel: 320-3445273

 1C32-CE	 1C41-CE	 1C42-CE	 1C42-D
 1C42-DT	 1C43-CE	 1C43-DT	 1C44-CE
 1C44-W	 1C46-A	 1C52-CE	 1C72
 1C72-A	 1C75	 1C83	 1C85
 1B92-A	 1B93-A	 1B93-A-40mm	 1B93-A-DT
 1B93-CDT	 1B93-20	 1B93-W	 1C42-FL
 1C42-FL-DT	 1C42-FL-1/4"	 2 X 2 X 3/8"	
 1C42-EZ	 1C42-EZ-1/4"	 2 X 2 X EZ	
 1C90	 1C33-45	 1C33-60	 1C33-90
 1C45	 1C54	 1C55	 1S14
 105 DEG.	 145 DEG.	 1N34	 1N35
 1S60	 D13-8mm	 D13-12mm	 D13-20mm RD/2

JUST A FEW OF OUR 500+ PROFILES

CERBACO LTD.

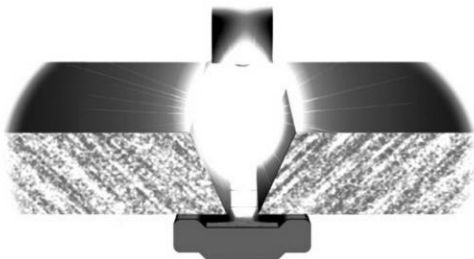

FROM THIS

TO THIS

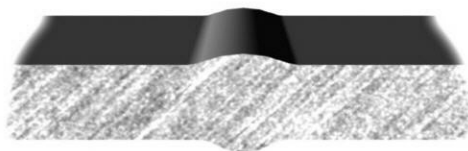

*WITHOUT GOUGING, GRINDING,
REWELDING, OR REWORK*

ACHIEVE:

*X-RAY QUALITY WELDS
FULL PENETRATION WELDING FROM ONE SIDE
UNIFORM BACK BEAD OF FINISHED QUALITY*

ELIMINATE:

*DEFECTS AND COSTLY REWORK
GOUGING AND BACKGRINDING
TURNING OVER HEAVY SECTIONS*

WELD:

*CARBON AND ALLOY STEEL
STAINLESS STEEL
NON FERROUS METALS
ALUMINUM*

*-STICK ELECTRODE
-MIG
-TIG
-SUB ARC
-FLUX CORE*

*-SHIPBUILDING
-STRUCTURAL STEEL
-PIPELINES
-PRESSURE VESSELS
-TANKS*

PRODUCT DESCRIPTION

In the past, full penetration welding involved costly backgouging, grinding, and rewelding. With CERBACO LTD. non metallic weld backings you can achieve X-ray quality, full-penetration welds from one side and in a single pass. The result is a finished high quality weld and a savings of labor, materials, and time. CERBACO weld backings are manufactured in many different configurations and in formulas for the diverse conditions encountered when welding anything from light gauge sheet metal to heavy metal fabrication. CERBACO weld backings can be used to compensate for poor fit-ups, and is a valuable tool when welding conditions are not ideal or where the back side of a weld joint is inaccessible.

CERBACO weld backings are non metallic, non hygroscopic, neutral, and unlike metal backing bars, do not become part of the finished weld. When properly positioned and attached to the back side of a weld joint, your welds can be free of defects eliminating rework and cleanup associated with poor root welds.

One-sided one-pass and one-sided muti-pass welds are possible with CERBACO weld backings. Our backings support molten weld metal over a wide range of welding heats resulting in uniform back beads of finished quality.

SERVICES

At CERBACO, we will provide complete technical assistance and will direct proper use of our products. If your application requires something special we will design custom shapes and sizes. In addition we will, if necessary, develop new backing formulations for you. In our 25 years of experience we have designed over 500 profiles. Typically, we stock many of these items in order to be ready for immediate shipment. All manufacturing is done by CERBACO. When an item is not readily available, it can generally be shipped within days from the time of order.

PROCEDURE

STEP 1. start with an open root:

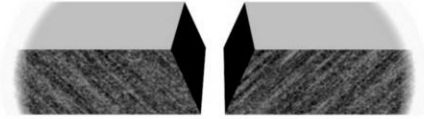

Backing will vary depending upon root opening, joint design and welding process

STEP 2. apply backing:

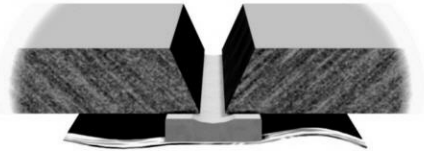

In most applications backing is applied using our adhesive foil on which the backing is assembled. The area to which the backing will be attached should be free of loose rust, dirt, and oil.

STEP 3. weld:



Establish your arc and weld a root pass.

STEP 4. remove backing to reveal finished backbead:

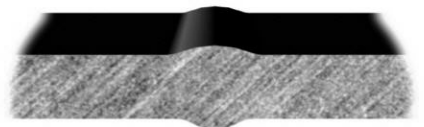

1C41-CE

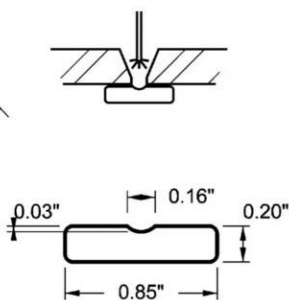
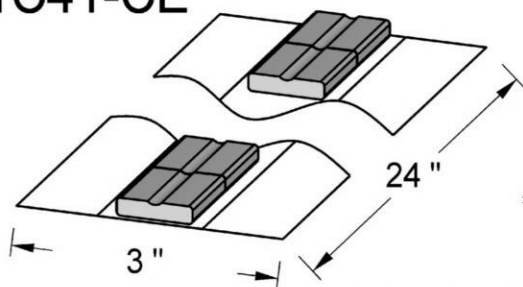

1C42-CE

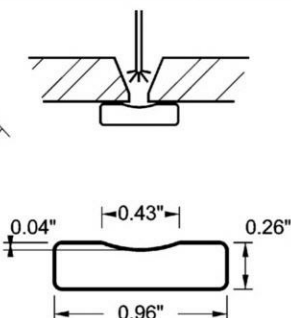
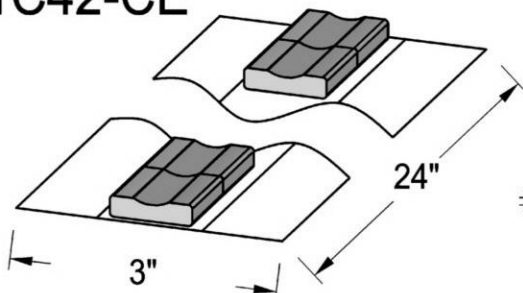

1C43-CE

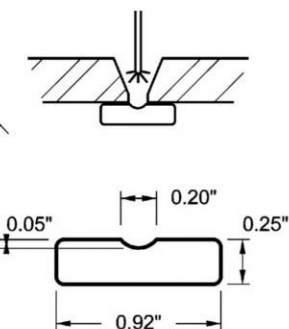
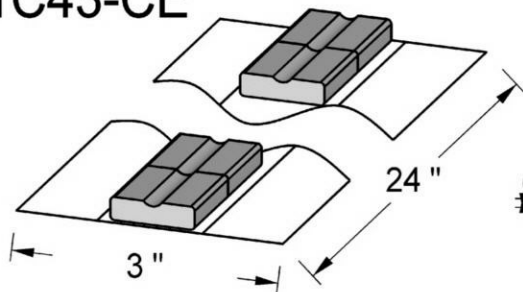

1C44-CE

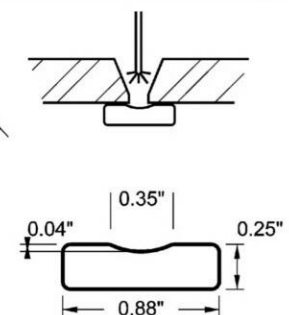
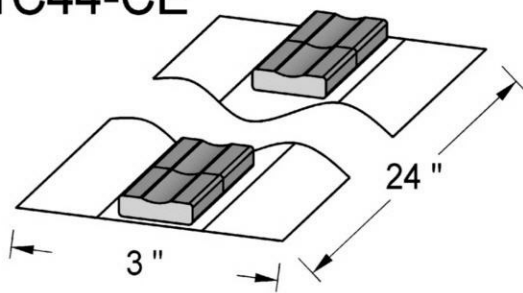

1C44-W

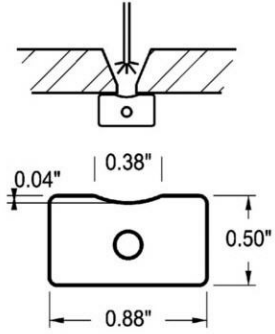
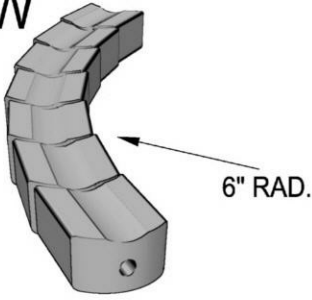

1C52-CE

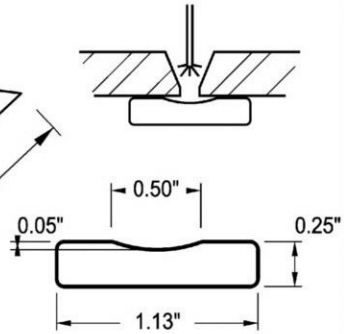
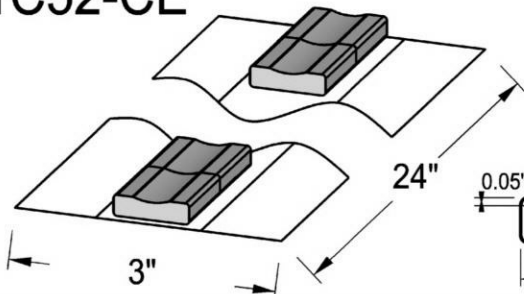

1C72

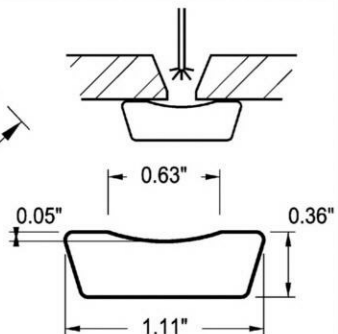
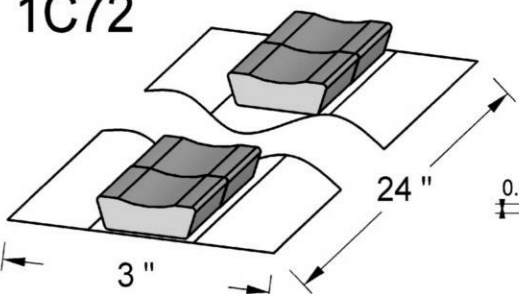

1C82-CE

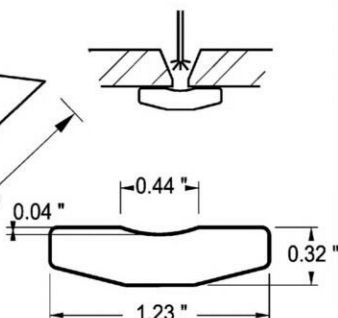
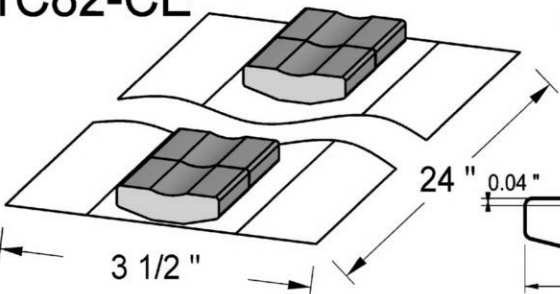

1C83-CE

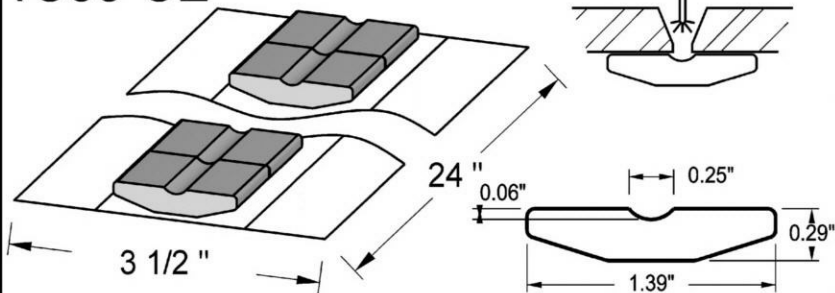

1C85

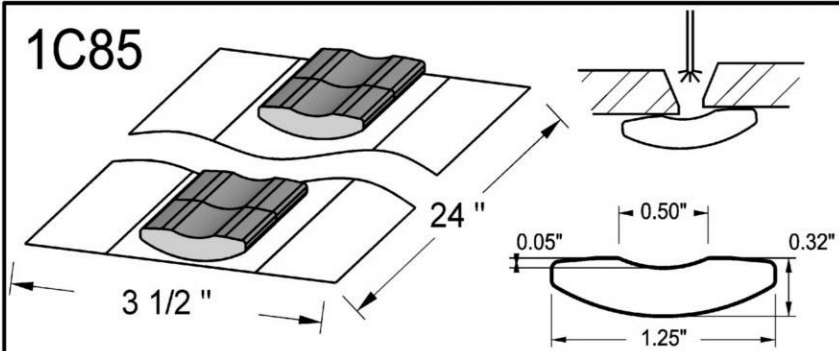

1B92-A

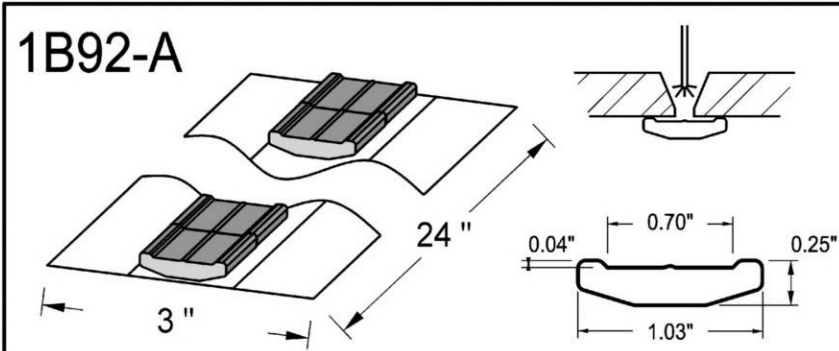

1B93-A

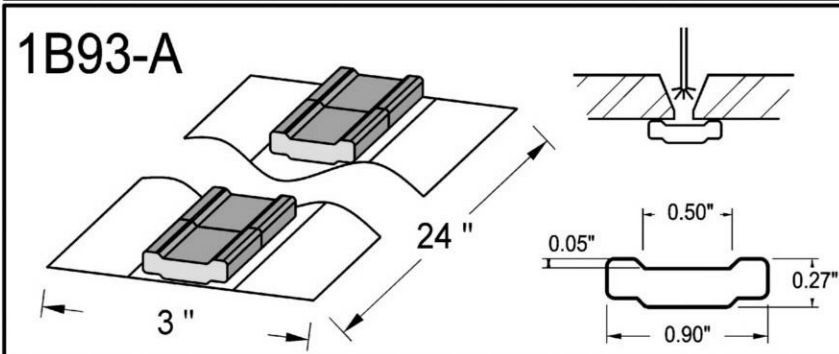

1B93-CDT

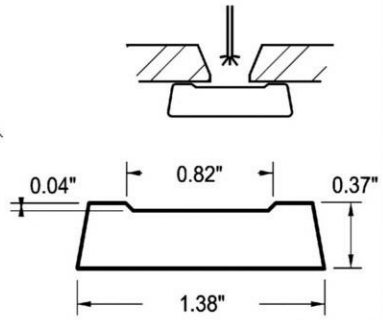
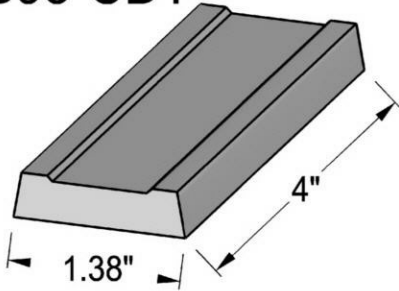

1B93-W

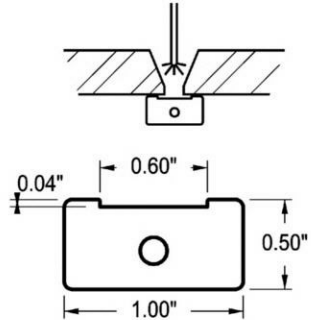
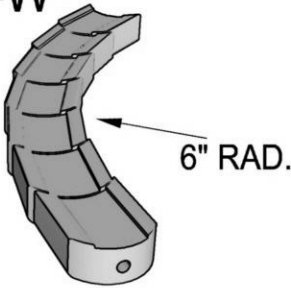

1C42-FL

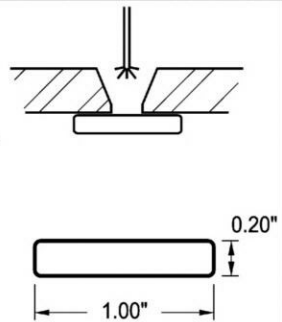
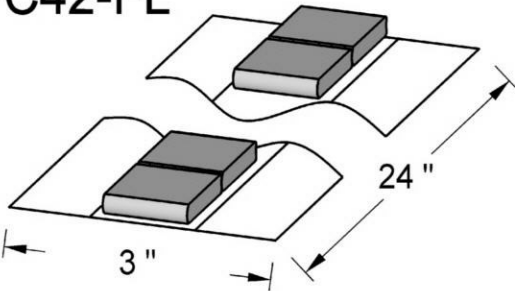

1C42-FL-1/4"

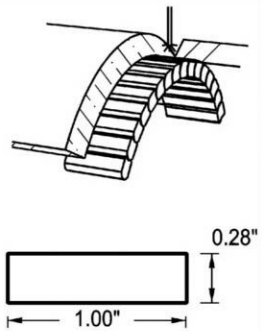
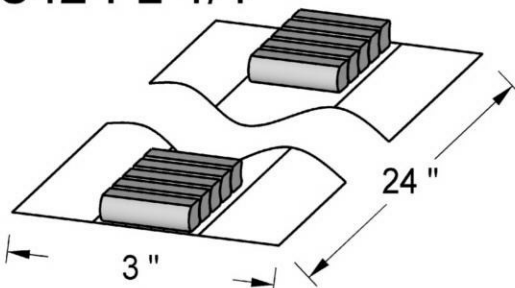

2 X 2

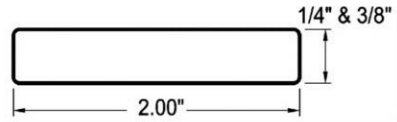
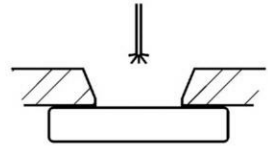
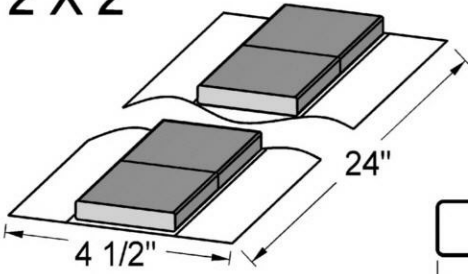

1C33-45

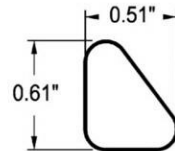
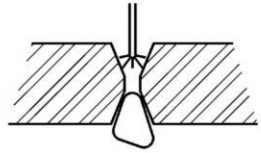
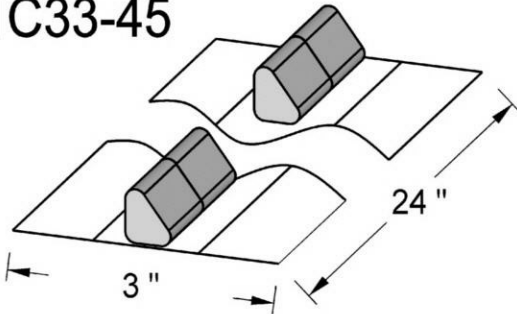

1C33-60

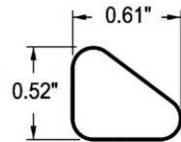
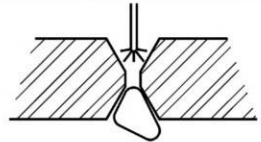
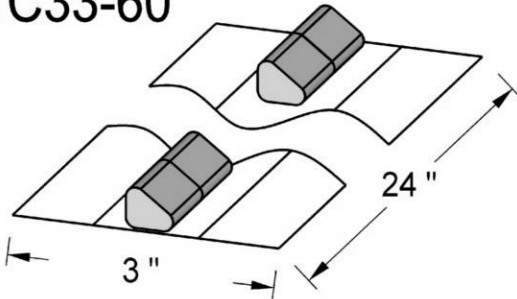

1C33-90

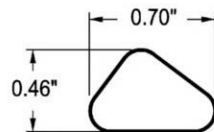
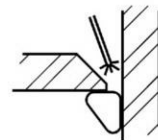
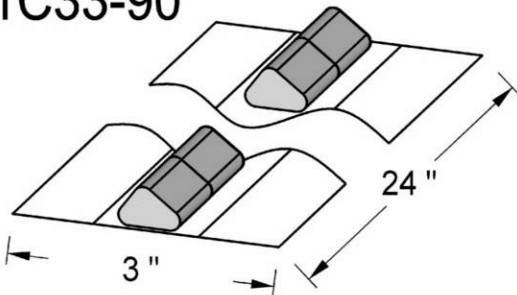

1C54

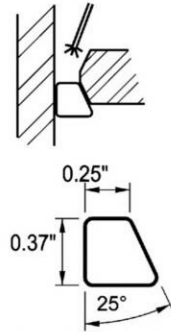
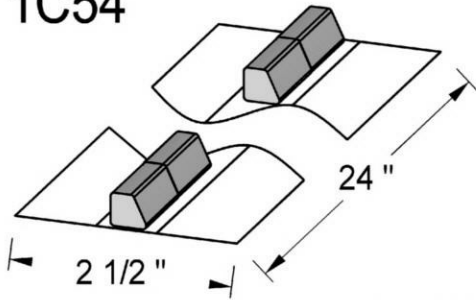

1C55

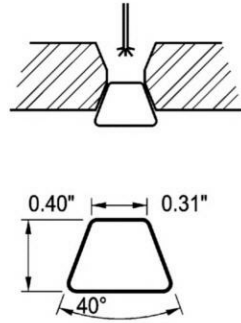
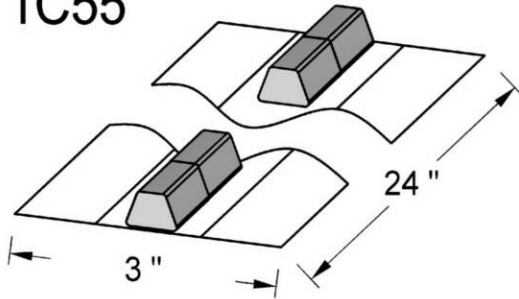

1S14

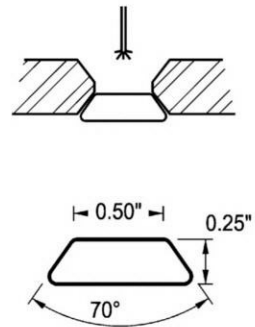
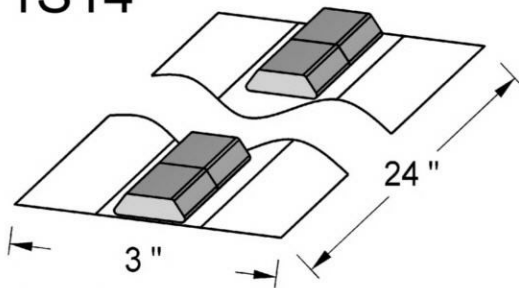

145 Deg.

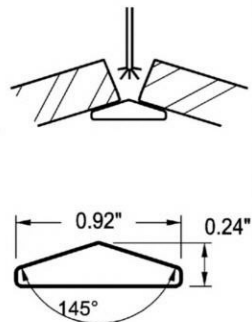
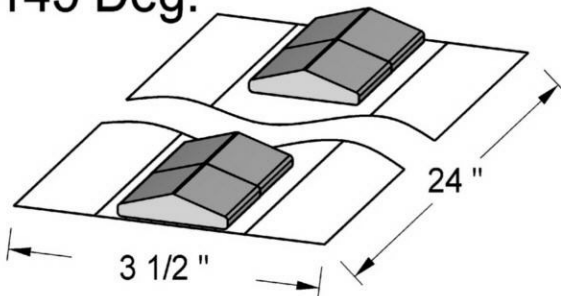

1N34

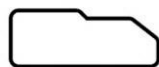
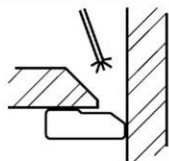
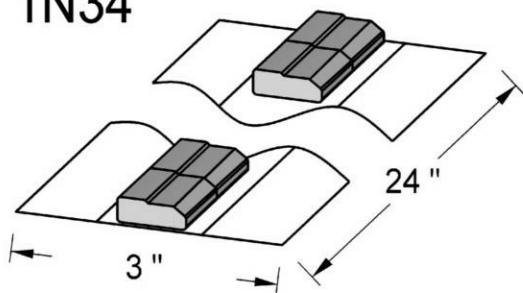

1N35

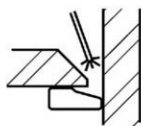
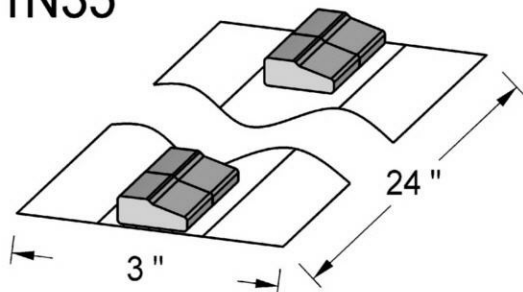

D13-(7mm to 16mm)

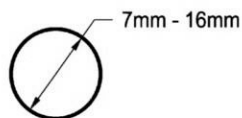
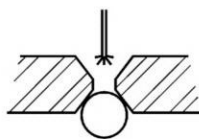
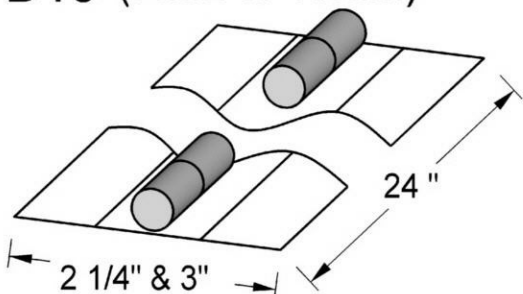

D13-(12mm to 20mm) RD/2

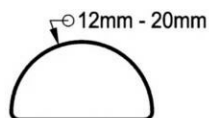
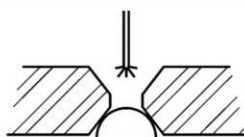
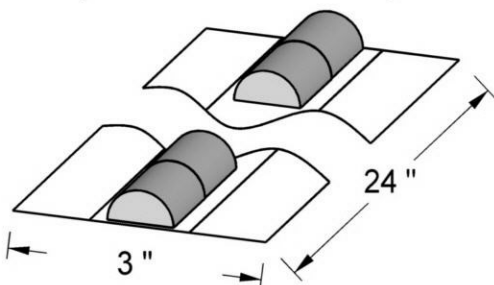

A range of CERBACO weld backings are available in varied metal track mounting systems supported by our magnetic clamps such as our 1C42-DT shown below.

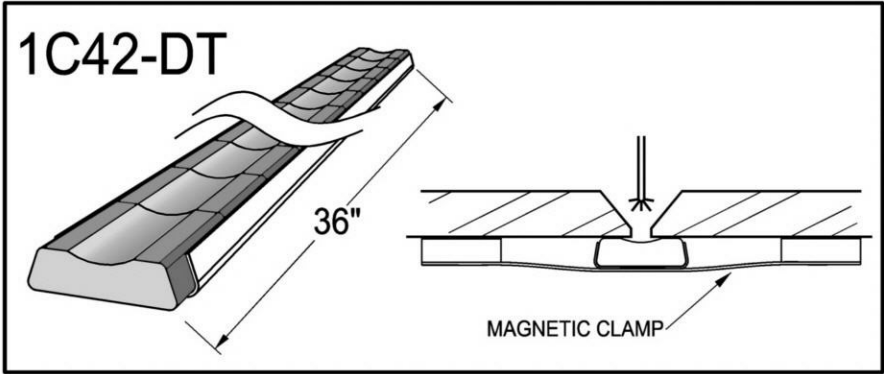

CERBACO also manufactures a line of flexible fiber backings for TIG welding of carbon and stainless sheet metal.

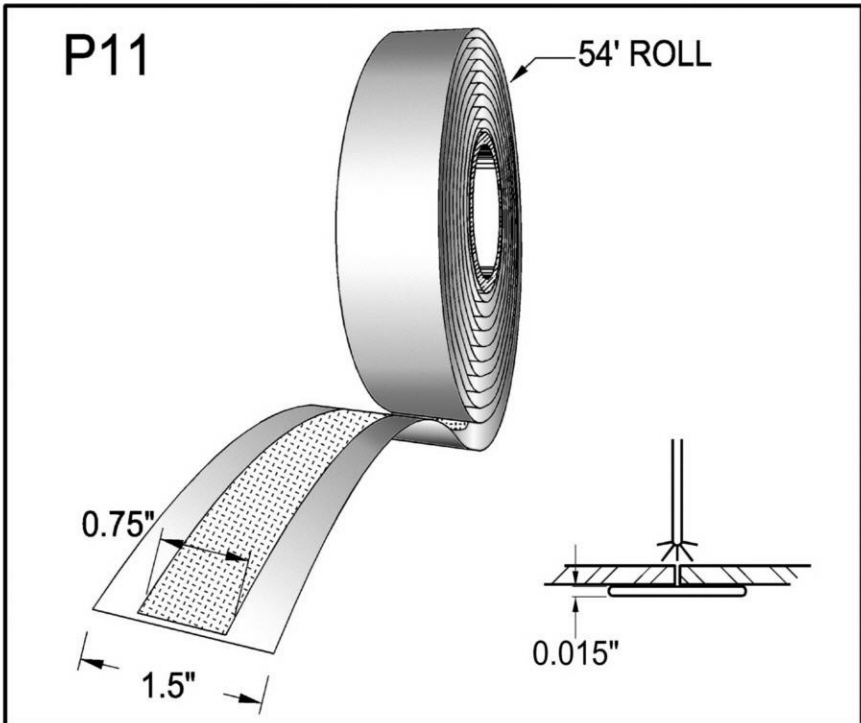

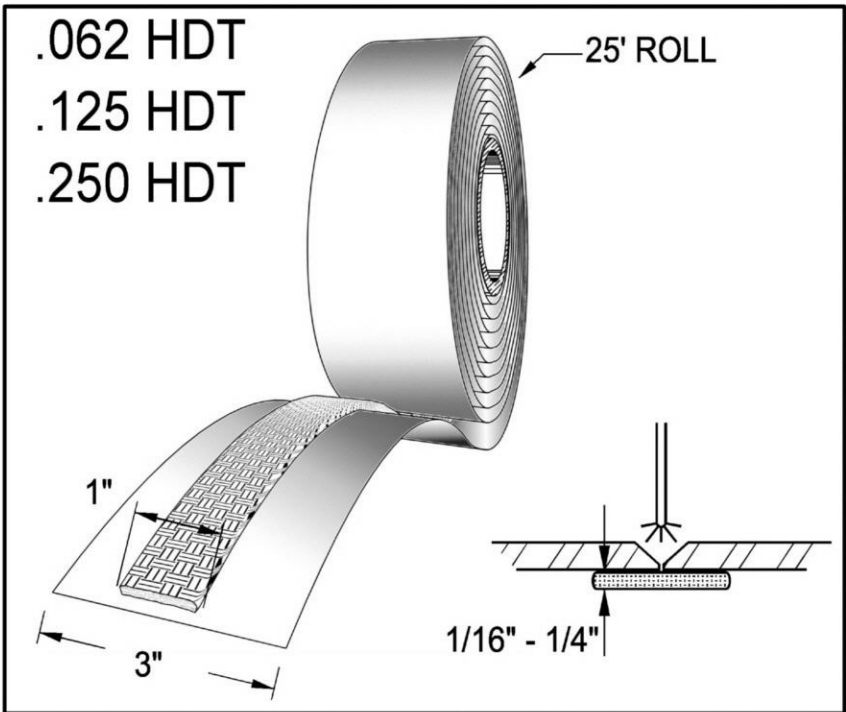
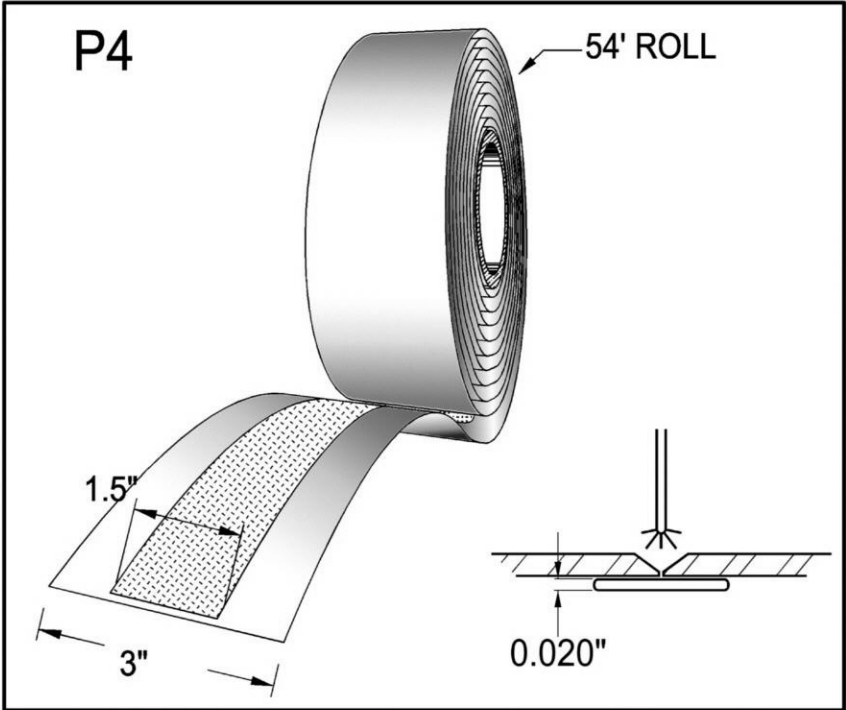

At CERBACO, we will provide you with the proper backing for your applications.

Our engineers will be happy to assist you in implementing the proper weld backing.

CERBACO can also develop new backings and formulations for your specific needs.



With a full range of shapes, formulations and mounting systems combined with our 25 years of expertise and customization, CERBACO LTD. is the one source for weld backings.

**CERBACO LTD.
809 HARRISON STREET
FRENCHTOWN, N.J. 08825
PHONE: 908-996-1333
FAX: 908-996-0023**

Distribuidor para Colombia:



www.daonte.com
info@daonte.com
Cel: 320-3445273

All text and images within this brochure are the property of Cerbaco Ltd. and may not be reproduced without the expressed written permission of Cerbaco Ltd.